

European XFEL Switchyard

W. Decking

CANDLE-PSI-DESY Collaboration Workshop

Yerevan, 30.06 - 02.07.2010



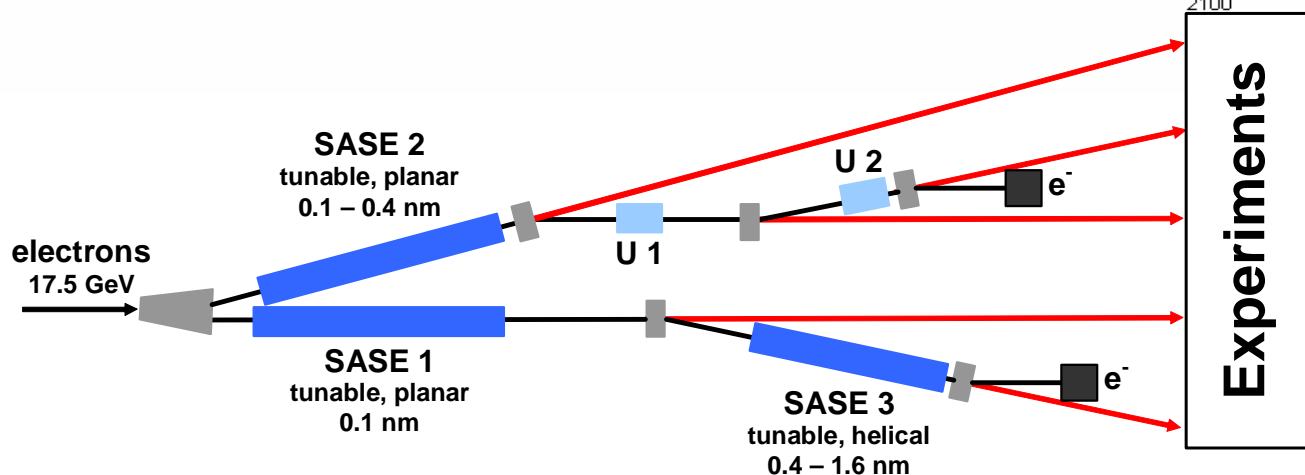
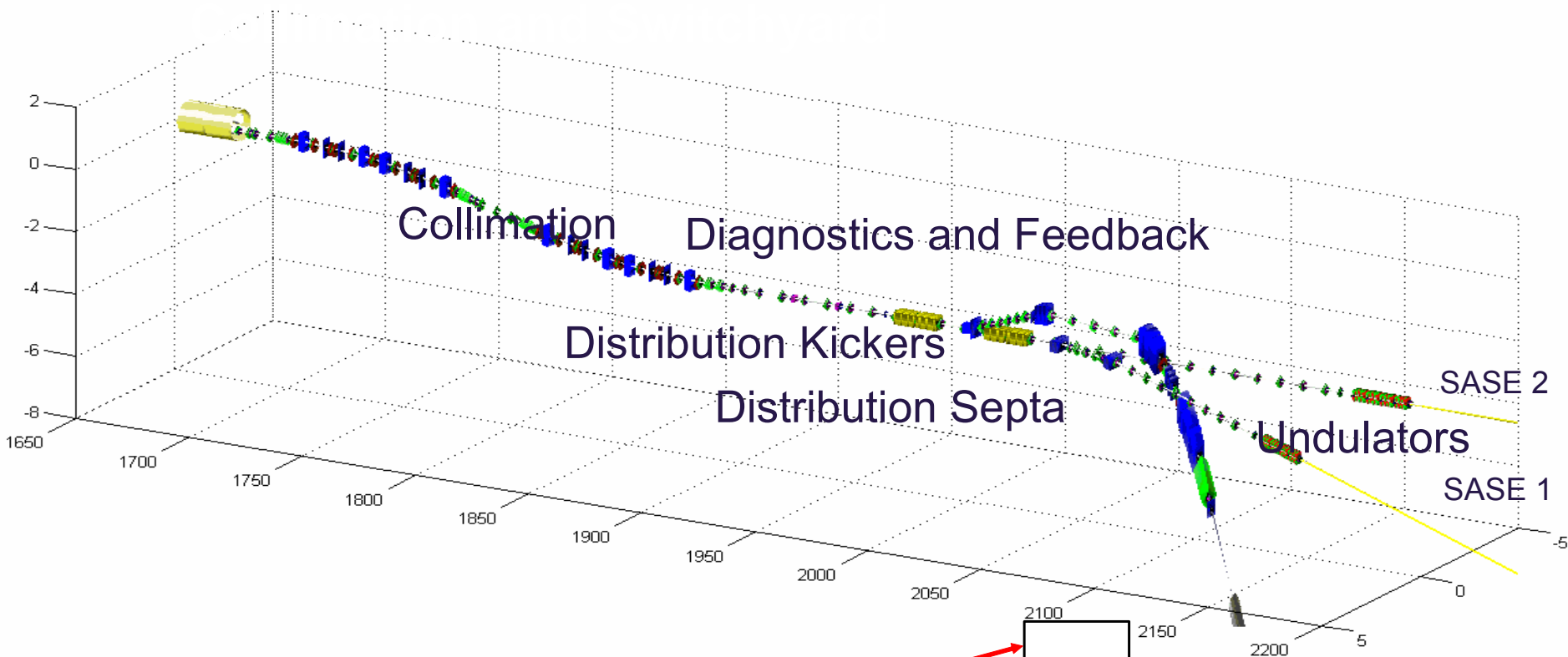
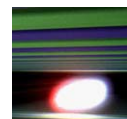

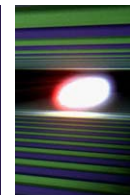

- Energies:
 - 6 GeV far future CW option
 - 14/17.5 GeV nominal operation
 - 22 GeV maximum envisioned energy range
- Energy bandwidth:
 - $\pm 1.5\%$ top quality acceptance
 - $\pm 2.5\%$ transport acceptance
- Bunch pattern:
 - 10 to 25 Hz Macro Pulse Repetition Rate
 - Up to 2700 Bunches/Pulse with 220 ns spacing (4.5 MHz)
- Different bunch patterns can be created at source
- But: linac is most stable with constant bunch pattern/beam loading

Pulse Pattern Options

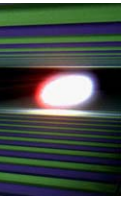

- All pulses in one beam line (max. beam power 300 kW !)
- One split per pulse into two beam lines
- Arbitrary patterns in each beam line
- Closely spaced bunches
(min. spacing 1 RF period = 770 ps)

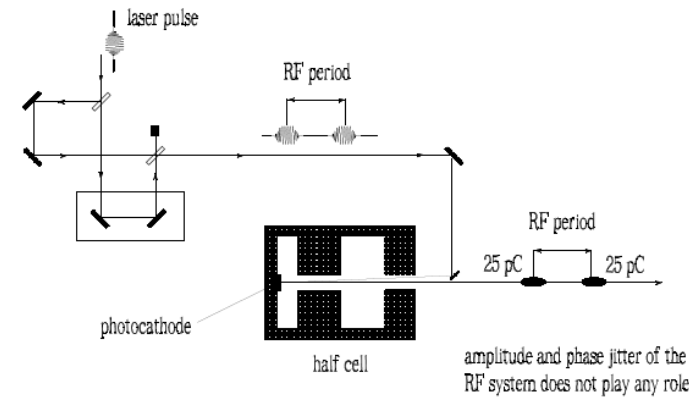

More Beam Distribution Options – ‘Fresh’ bunch

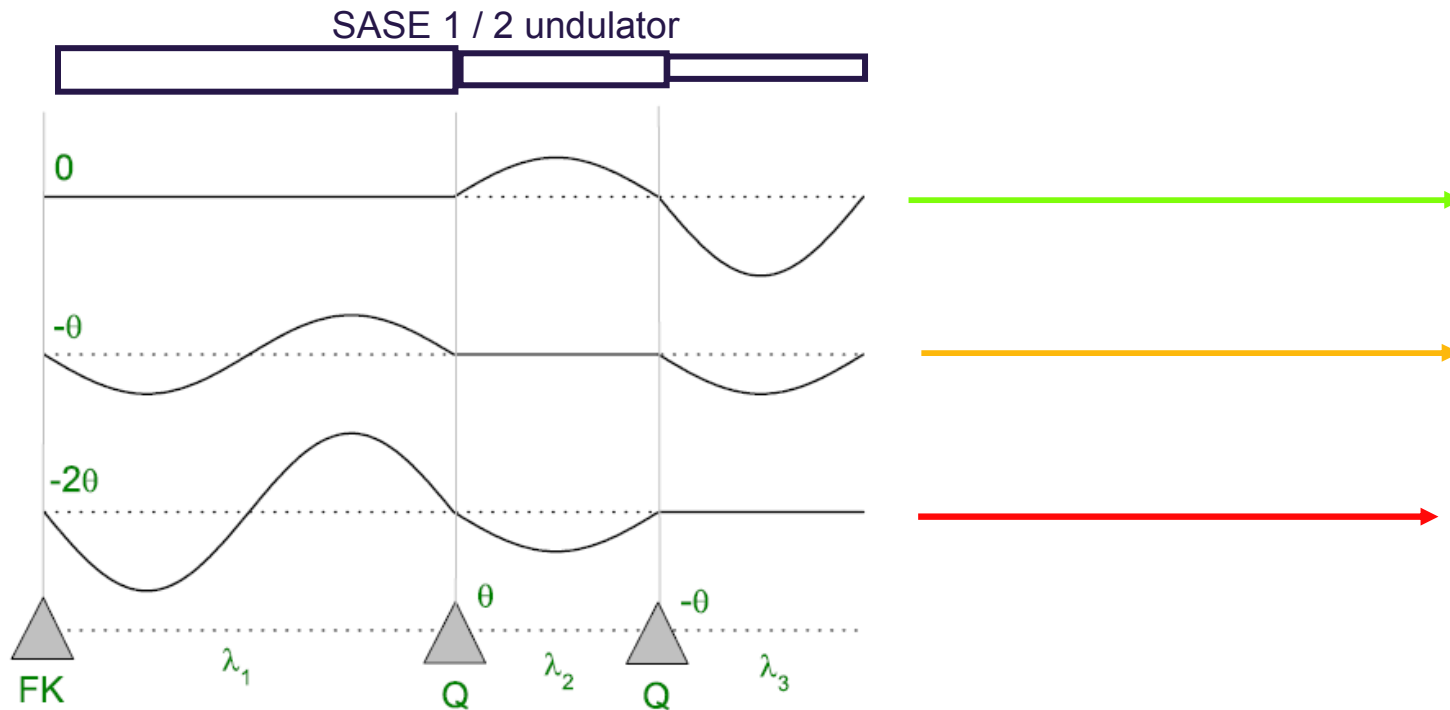
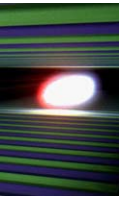

Fast Kicker

Corrector

Corrector

- Reasonable in one undulator only if $L_{\text{und}} > L_{\text{sat}}$
- Bunch to bunch switching possible
- Separate beam lines ($\theta \approx 10 \mu\text{rad}$) possible ?
- ‘De-coupled’ operation of SASE1 and SASE3 obviously possible

Energy Variation – Within Bunch Train

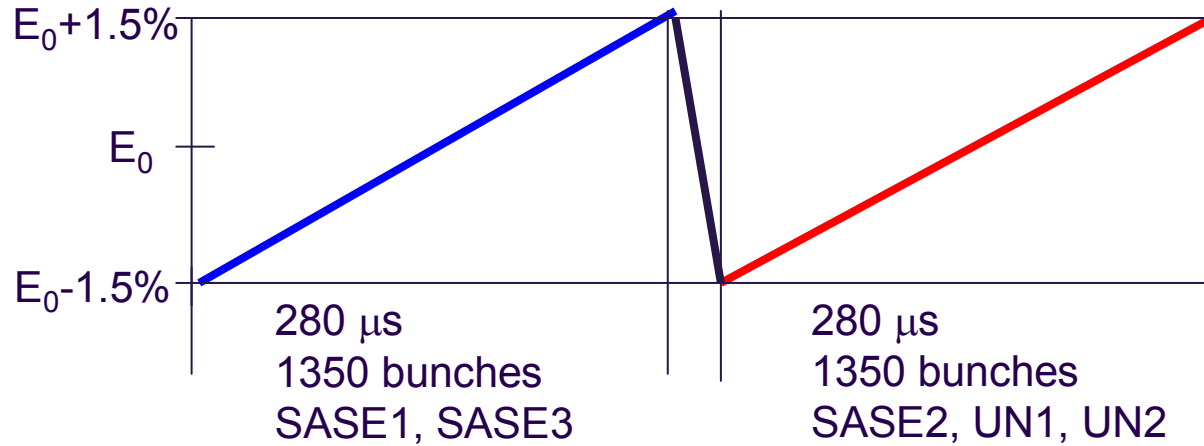
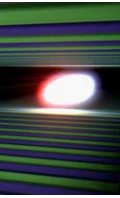

$$\Delta E/E_{\text{max}} = 3 \%$$

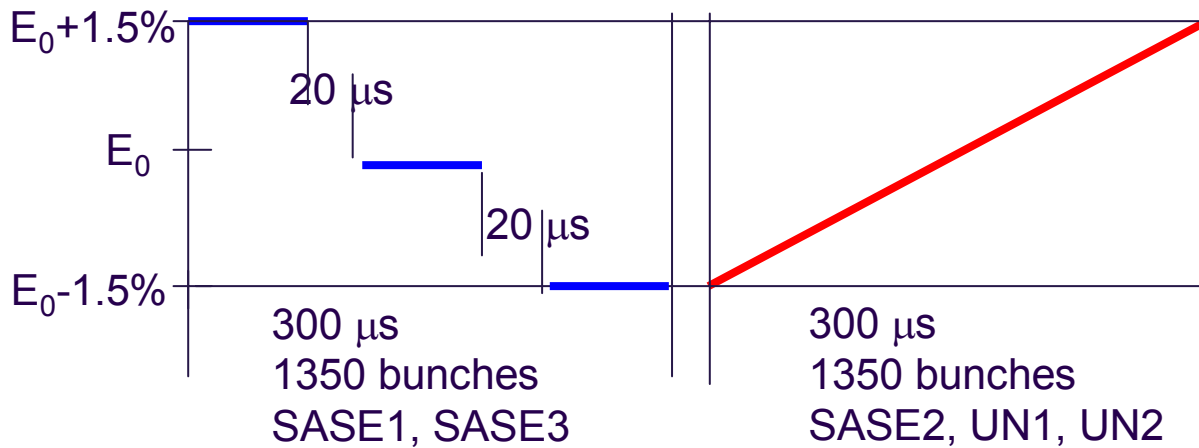

$$\Delta E/E = + 10^{-4} / \mu\text{s}$$

$$- 10^{-3} / \mu\text{s}$$

Energy Variation – Bunchtrain to Bunchtrain

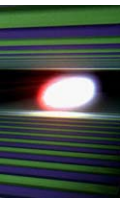

- Follows similar pattern within the $\pm 1.5\%$ bandwidth

- Larger energy variation requires magnet scaling
 - same change for all beamlines
 - time scales in seconds (one direction) to minutes (other direction)
 - fast regaining of SASE only possible with 'well' behaved phase space

Electron Beam Switch

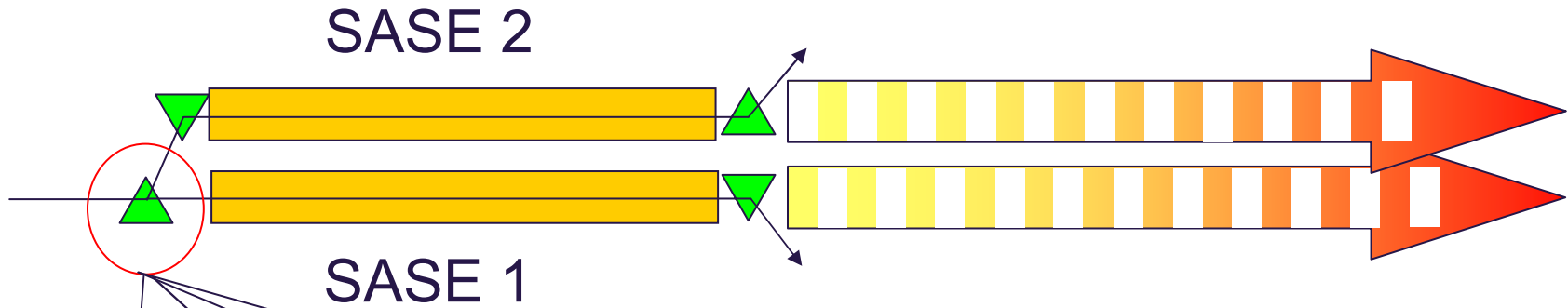
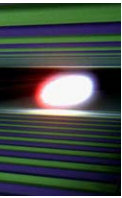

<p>DC Magnet</p> <p>One beamline only</p> <p>Commissioning option</p>	<p>Slow switch pulse to pulse</p> <p>Duty cycle reduced by # beamlines</p> <p>TDR option</p>	<p>High Q Resonator</p> <p>Fixed bunch pattern, full duty cycle</p>	<p>Programmable fast kicker for individual bunches</p> <p>Flexible</p>
---	--	---	--

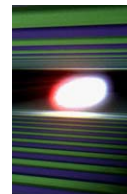

Use fast kicker to deflect beam far enough to employ septum magnet with field free region for straight beam and large field for deflected beam

$$\begin{aligned}\Delta &= x_{\text{septum}} + 2m_{\text{collimation}} \sqrt{\varepsilon \beta_{\text{septum}}} \\ &= \Theta_{\text{kicker}} \sqrt{\beta_{\text{septum}} \beta_{\text{kicker}}}\end{aligned}$$

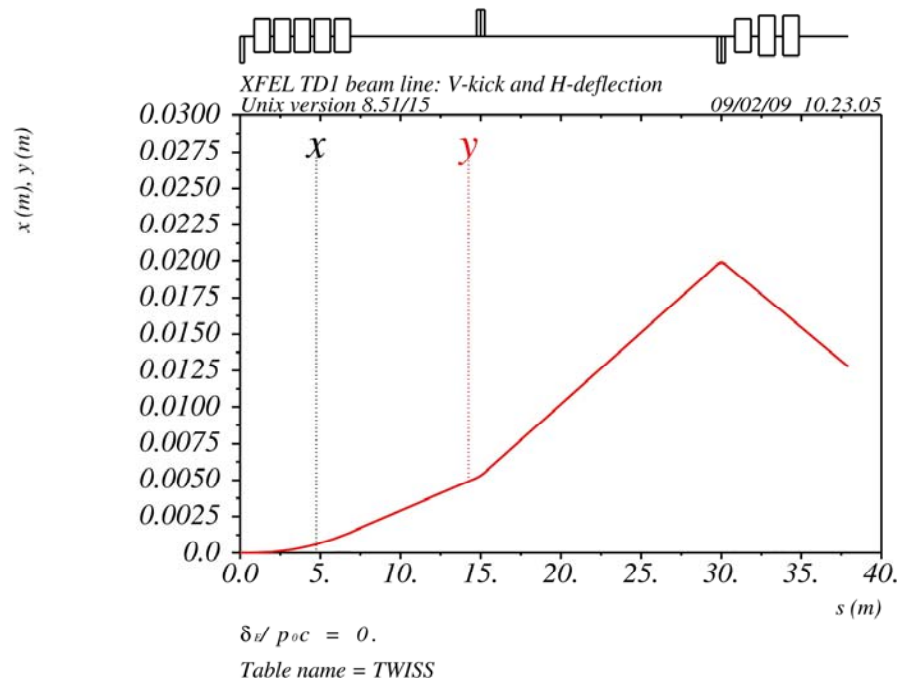

- Stability goal at undulator $< 1/10 \sigma$
- Kick strength approx $300 \sigma \Rightarrow$ rel. amplitude stability $< 3e-4$
- Septum deflection approx $4000 \sigma \Rightarrow$ rel. amplitude stability $< 2.5e-5$
- Stability goal at dump $< 10 \sigma \Rightarrow$ rel. amplitude stability $< 3e-2$

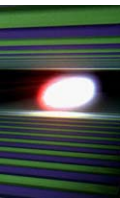

- Kicker-Septum Scheme
- Stable flat-top kicker distributes between beam lines
- Fast burst kicker deflects into dump for arbitrary bunch pattern and emergency beam abort
- Linac operates with constant beam loading

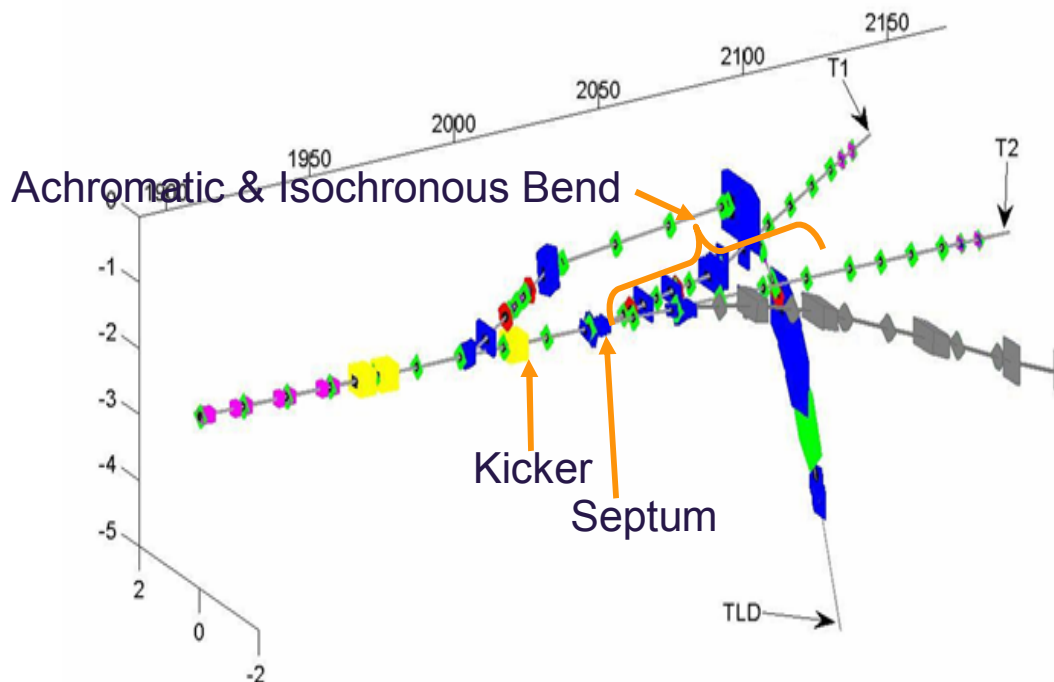

Beam Switchyard cont.

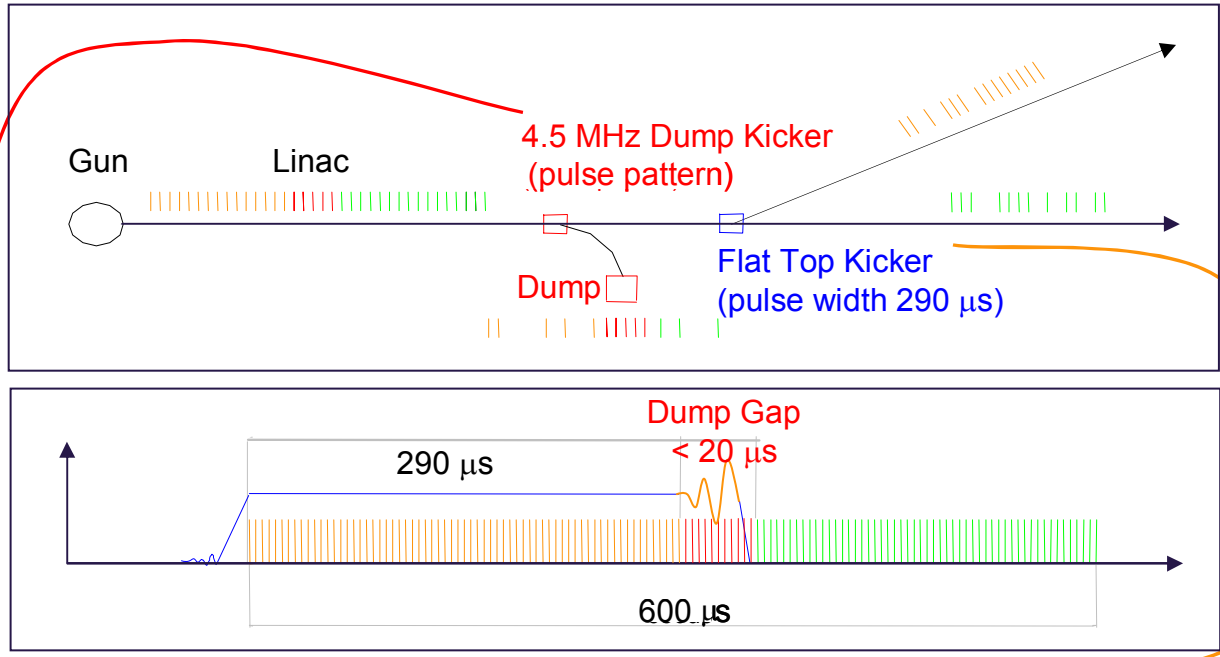
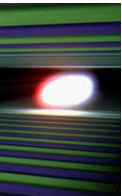

- low accuracy (>1 %)
- 4.5 MHz burst operation

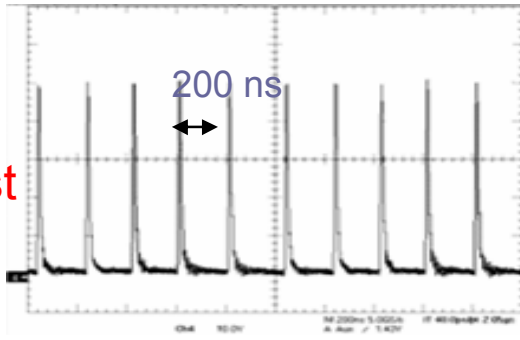

example:
pulsar prototype measurement

- high accuracy (< 0.01 %)
- 10 Hz operation

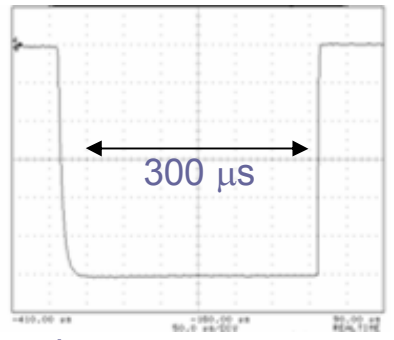

example:
pulsar prototype measurement

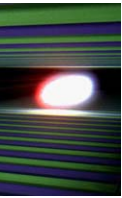

A-A (1:1)

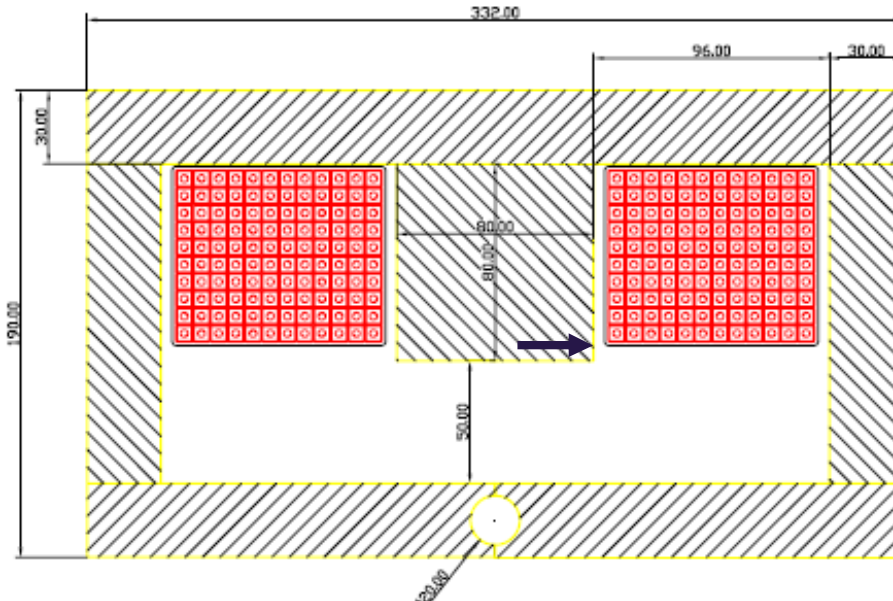

Lambertson DC Septum

160 A, 5 kW

- 'Classical' electro-magnet
- Needs orthogonal kick

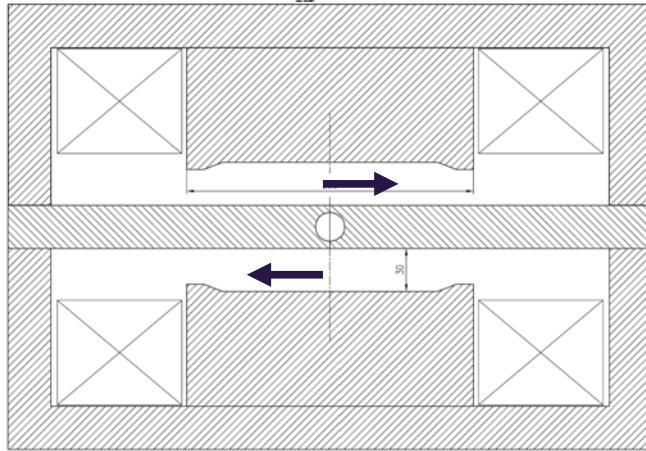

Variant: Twin Septum for deflection to TD1 and TD20

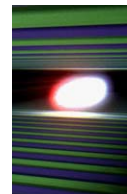

Current Sheet AC Septum

8 kA pulsed

- Pulsed operation
- Integrated into vacuum system

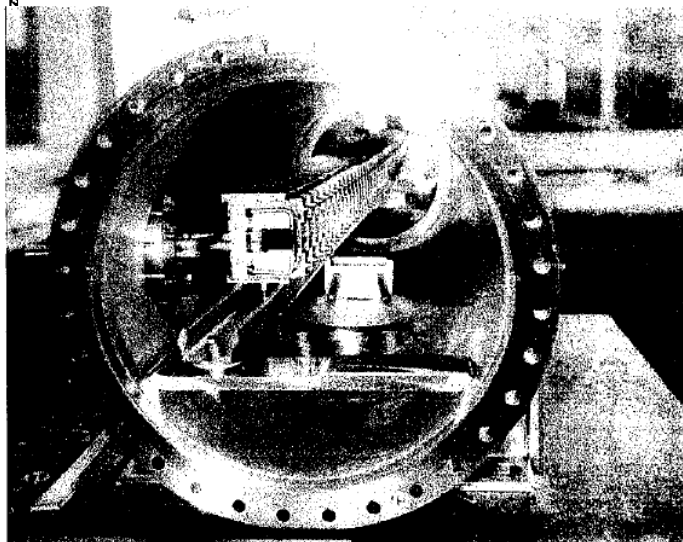
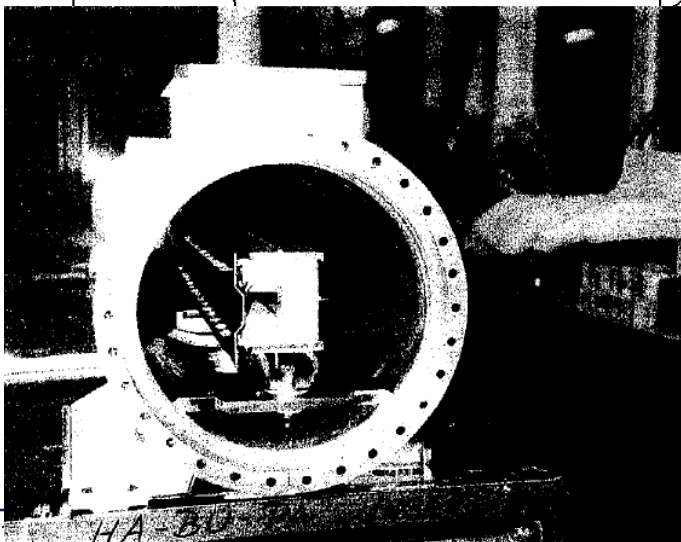
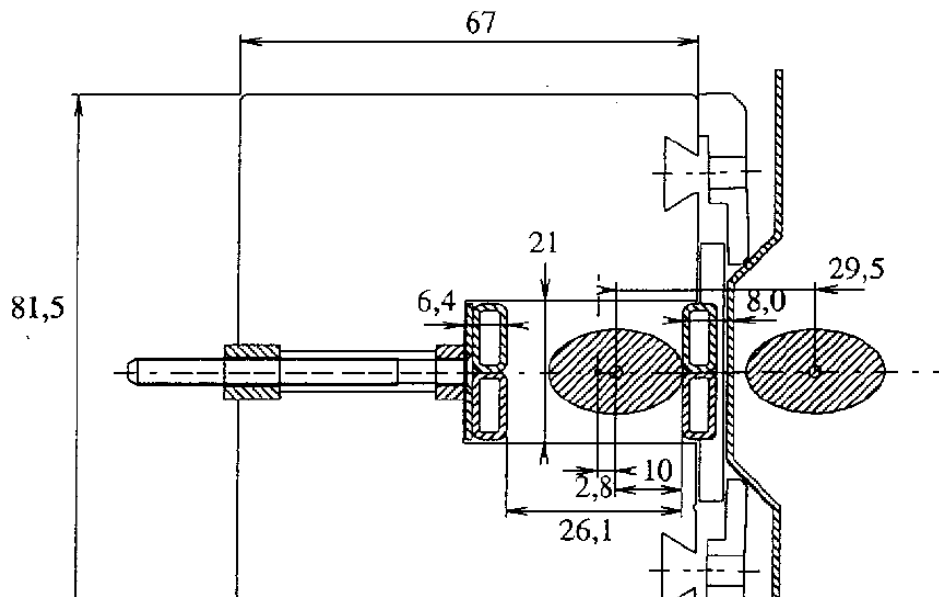

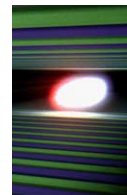

- DC current sheet septum ruled out because of excessive power needs both within magnet and power supply line
- AC current sheet septum preferable in terms of vacuum integration, but concern about stability ($1e-6$ required)
- Lambertson DC septum technically most robust, orthogonal deflection manageable (see next talk), vacuum integration worked out

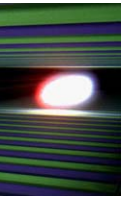

In-house development

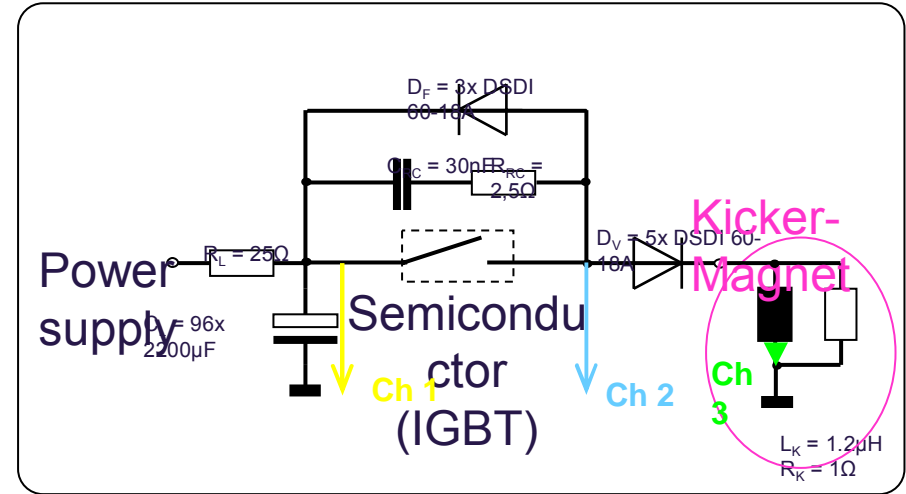
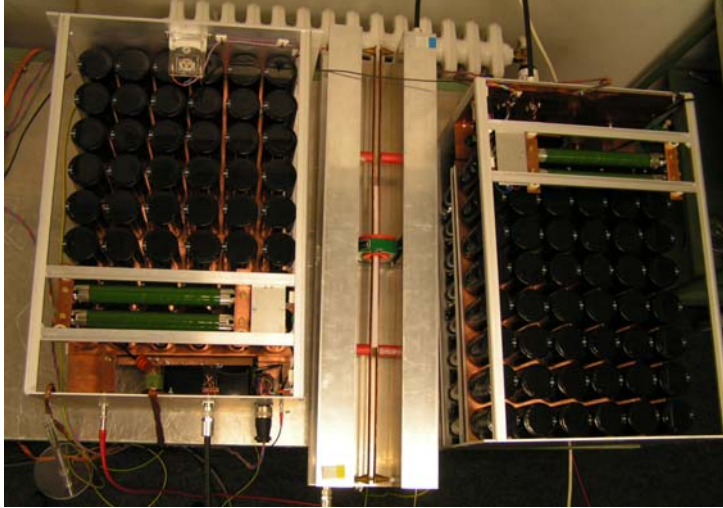

FLASH Measurement

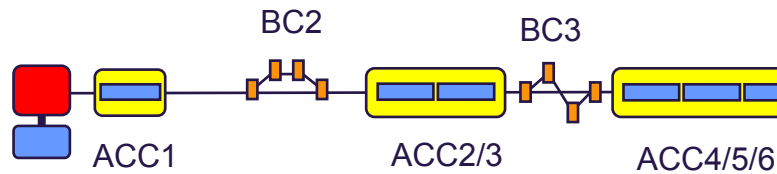

installed on one of the FB kickers
closed bump with 2 downstream VSTEERERS

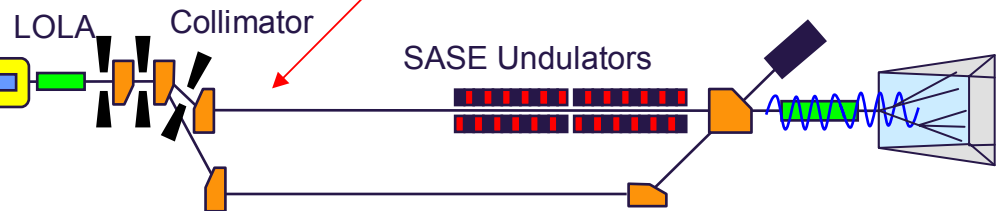

Flat Top Pulser – FLASH Measurements

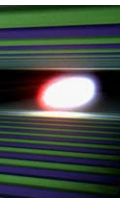

Amplitude Calibration: 0.024 mTm/V
(as expected)

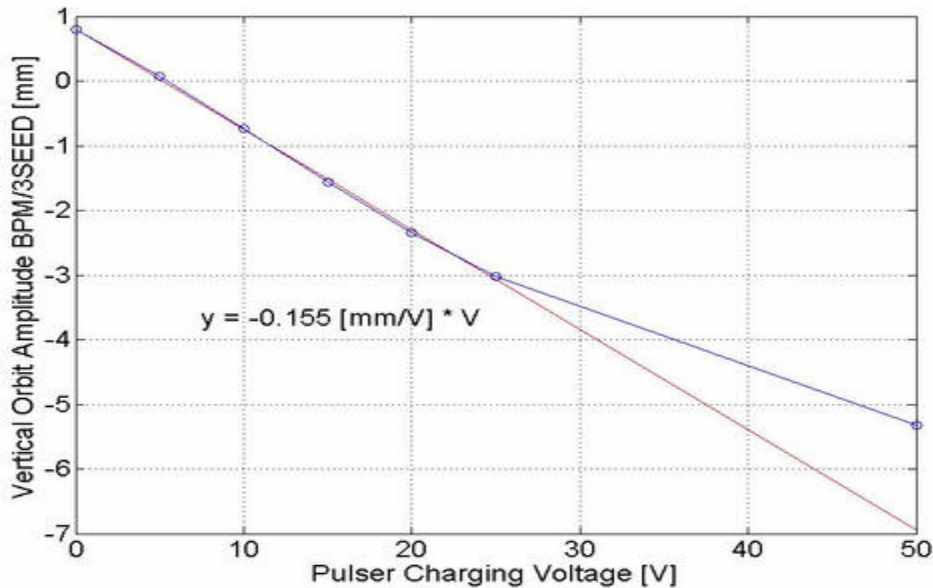

... and maintains SASE

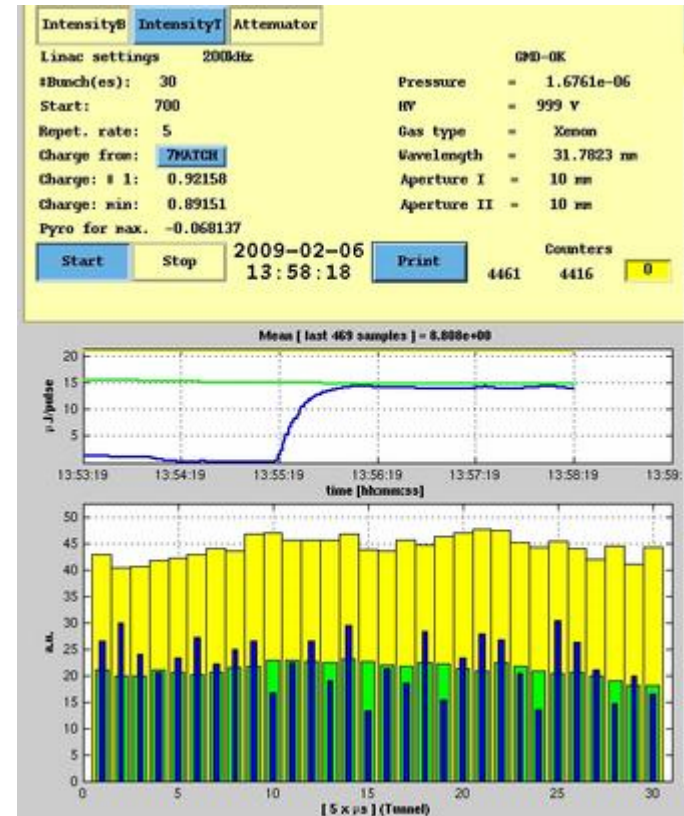

FLAT Top Pulser – Kick Stability

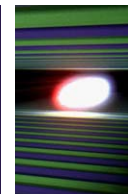

Beam Position Jitter over 1000 pulses without/with flat top pulser

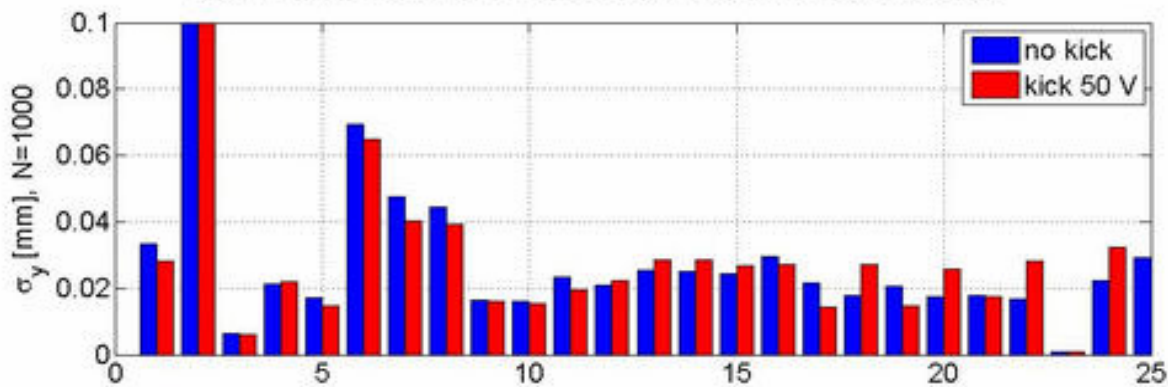

RMS stability with beam:
 $< 4e-3$
 (resolution limited)

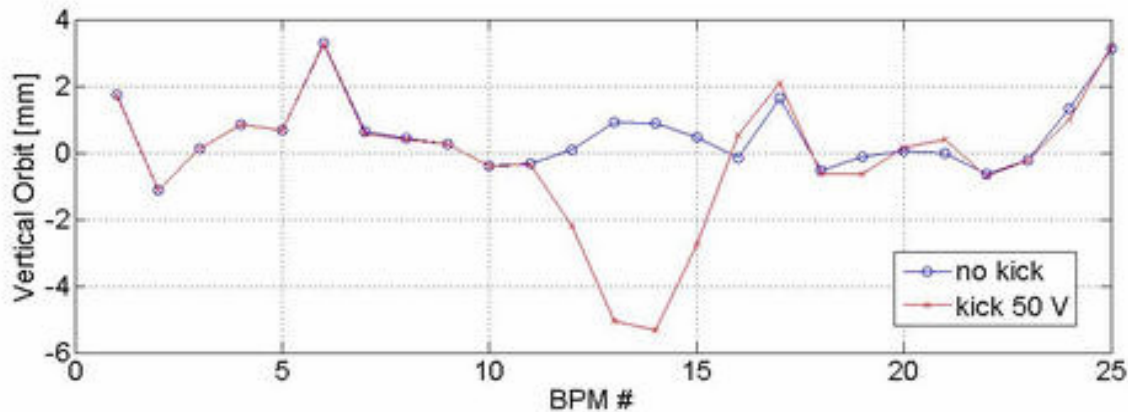

FLAT Top Pulser – Kick Stability

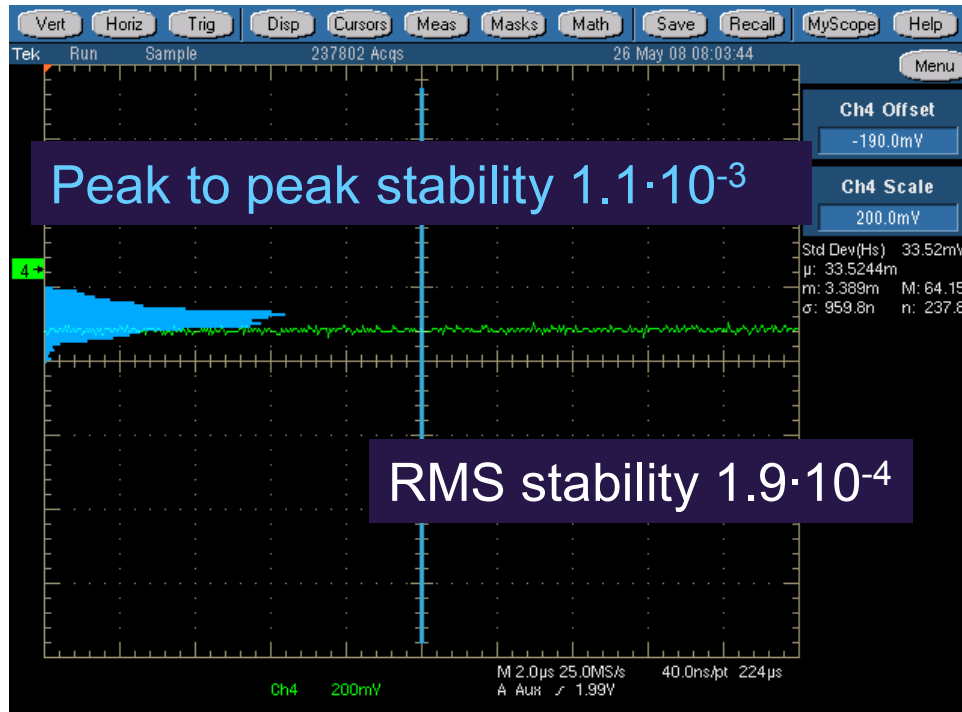
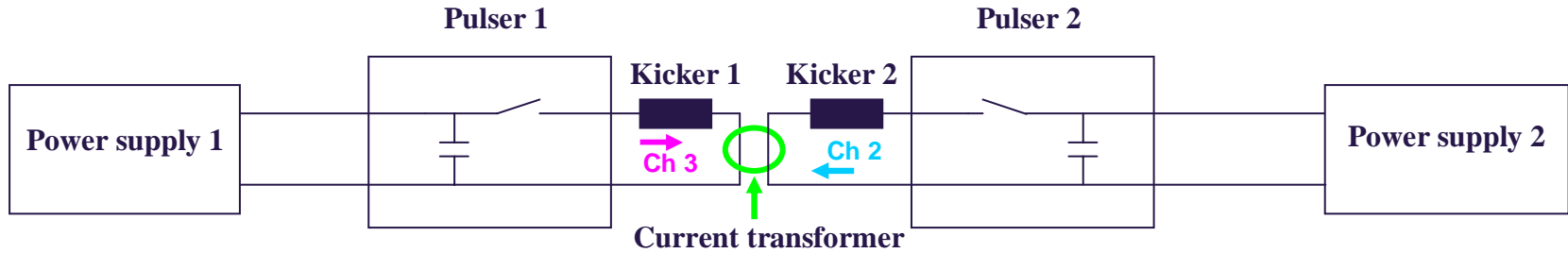
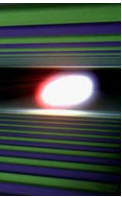

Statistics: 2.5 days

FAST Pulser

Company built pulser and in-house kicker

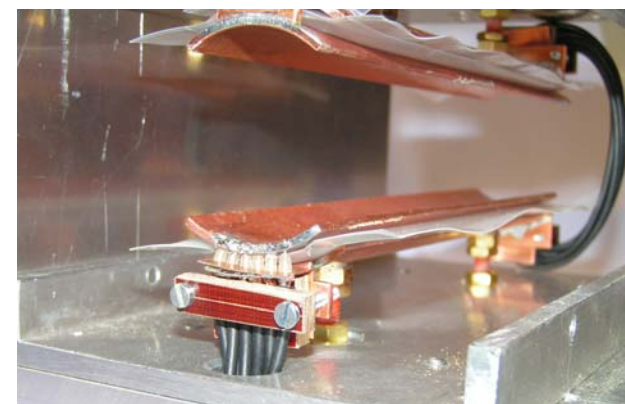
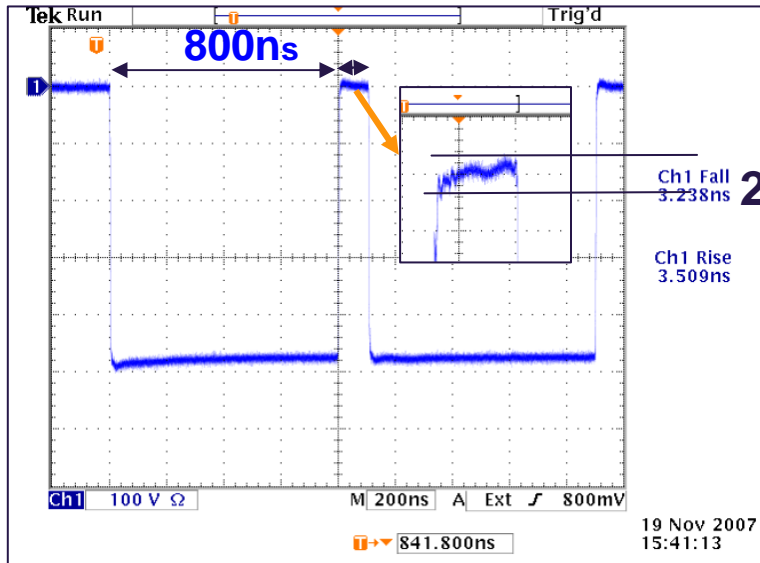

FLASH Measurement

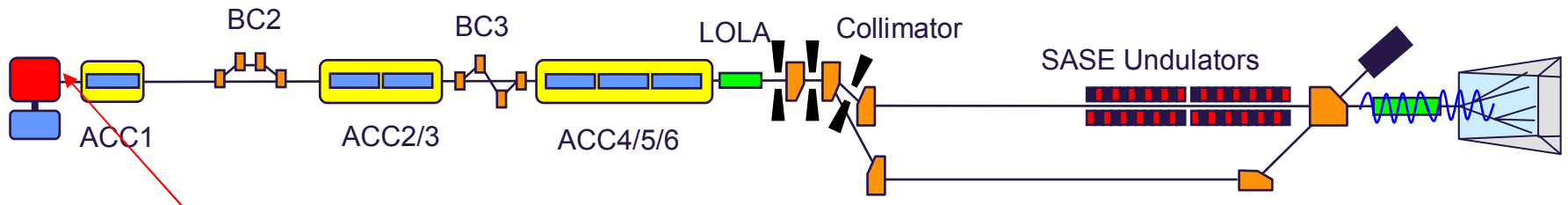

installed after the gun to be used as dark current kicker

Fast Pulser – Pulse Profile

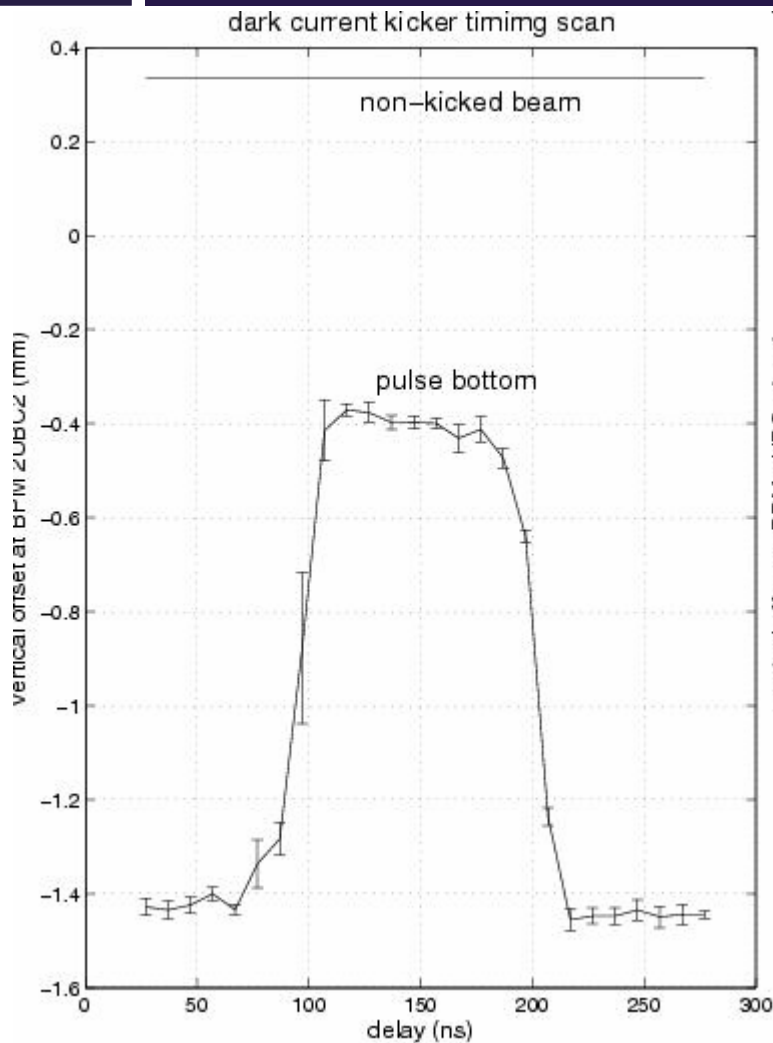
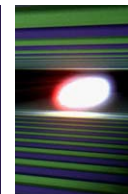

non-zero pulse bottom

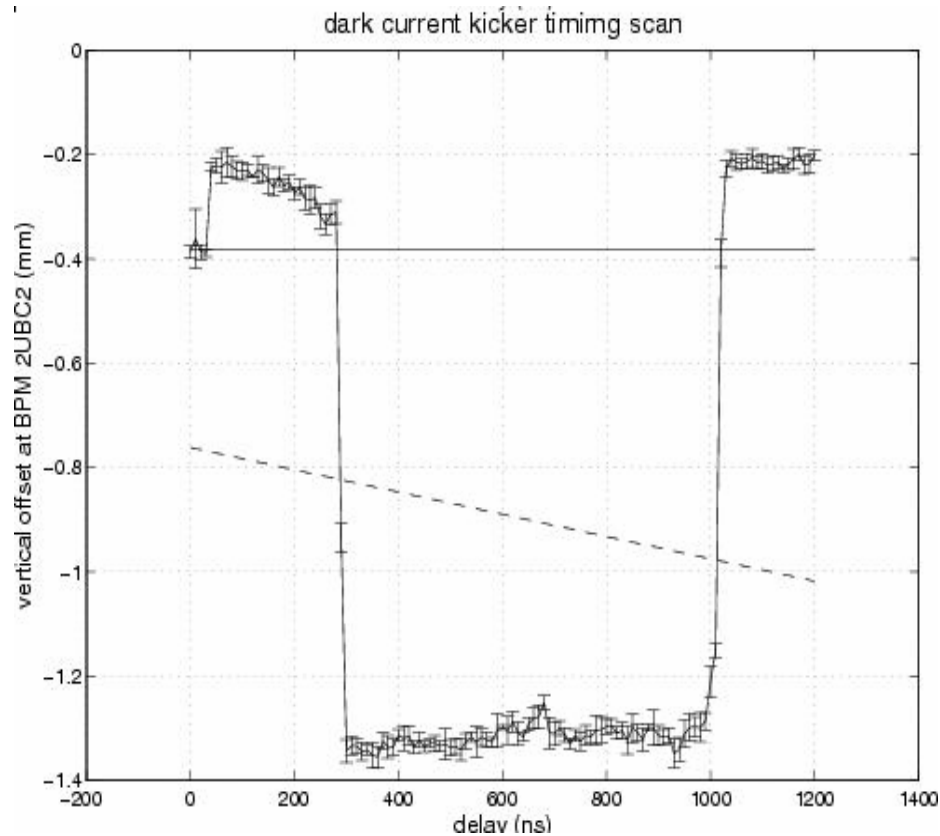

cannot distinguish between
beam/kicker jitter

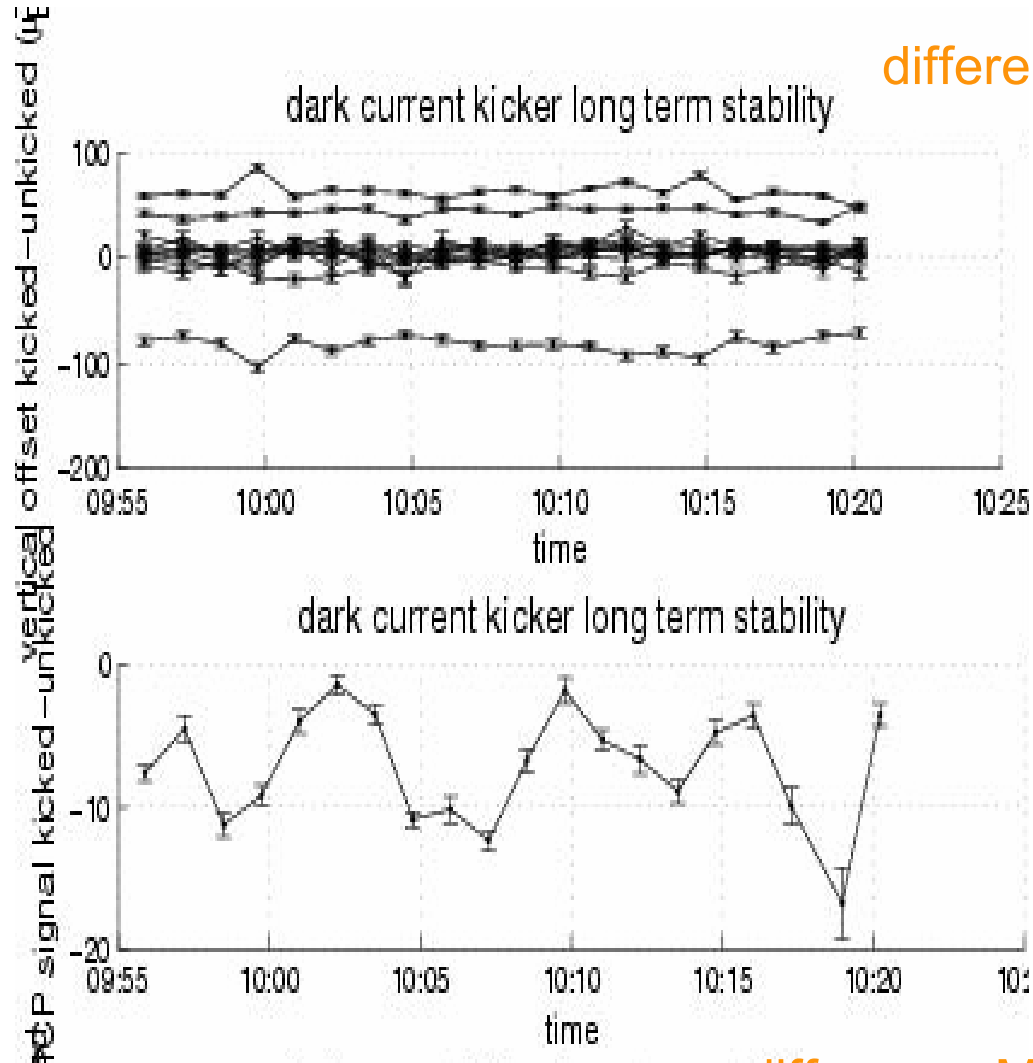
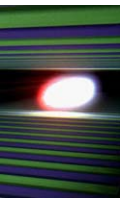

- estimated stability about 1%, but measurement hampered by large residual kick in flat bottom
- SASE drops only by about 5% (with little tuning)

difference MCP kicked-not kicked

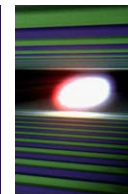

	Deflection to Beam Dump	Deflection to TD1 Undulator Line
Kicker		
Pulse Form	Burst	Flat top
Repetition Rate	5×10^6 Hz	10 Hz
Max. Pulse Width	200×10^{-9} s	300×10^{-6} s
Rise/Fall Time	$< 100 \times 10^{-9}$	$\approx 20 \times 10^{-6}$ s
Rel. Amp. Stability	0.01	3×10^{-4}
Rel. Residual Ripple	3×10^{-4}	3×10^{-4}
Kick angle	0.5 mrad	0.5 mrad
Int. Field at 20 GeV	33.4 mT m	33.4 mTm
Kicker aperture	24	24
Kicker Type	Strip Line	Strip Line
Kicker active length	0.5 m	1 m
Number of kickers	16	5
Pulser Voltage	8 kV	100 V
Pulse Current	80 A	250 A
Septum		
Septum Type	Lambertson	DC
Deflection angle	35 mrad	20 mrad
Device Length	4 m	4 m
Int. Field at 20 GeV	2.35 Tm	1.33 Tm
Septum Bar Width	5 mm	5mm
Rel. Amp. Stability	1×10^{-4}	1×10^{-6}

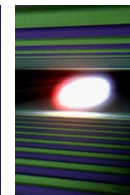

- Kicker – Lambertson DC Septum Scheme selected because of robustness and stability performance
- Distributed Dump/Beamline kick for enhanced stability
- R&D on both pulser types ongoing
 - Flat top pulser 2nd prototype (= almost final) this year
 - 2nd prototype of fast pulser this year
 - Biggest issue: after pulse jitter
- Optics -> next talk